

# MICRON MOLD CHUCKS - USE & CARE INSTRUCTIONS

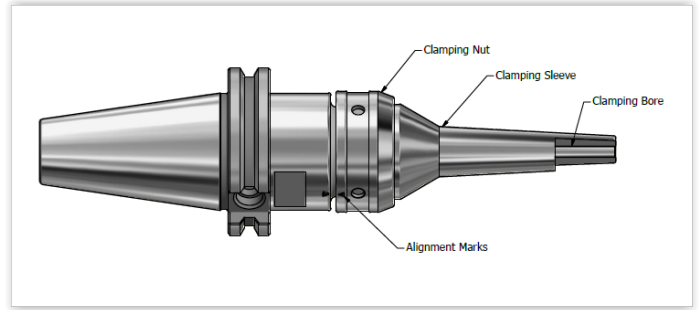

## SAFETY & CARE

- As with all tooling and machining products, care must be taken to prevent injury or damage from improper use.
- As with all tooling and machining products, cleanliness and proper storage are necessary to extend the life and precision of these products.
- Please read and understand these instructions before operating the tooling.
- Rotate clamping nut fully, counter-clockwise to align marks. Remove clamping nut & sleeve. Apply moly grease to clamping zone of body every 20 tool clampings. (see diags. below)

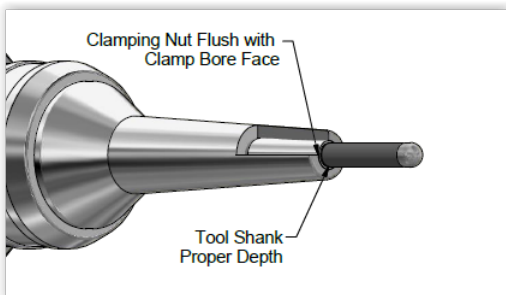
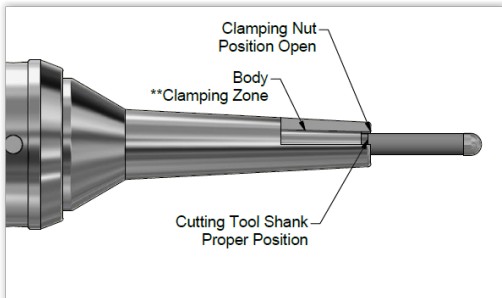

## MICRON MOLD CHUCK DESCRIPTION

- Clockwise rotation of clamping nut tightens the clamping bore to hold the cutting tool. When properly tightened the Clamping Nut will be flush with the chuck nose. Do not clamp beyond flush. Do not over tighten to the point the Clamping Nut bottoms-out on the chuck body.
- Counter clockwise rotation of clamping nut loosens the clamping bore to release the cutting tool. Rotate until the Clamping Nut stops against an internal pin. Do not force beyond.
- Clamping the Micron Mold Chuck without a tool or clamping a tool with a notch or flat in the clamping bore can cause damage reducing precision and force.

## CUTTING TOOL INSTALLATION & CLAMPING

- Clean all surfaces of remaining contaminants or shipping oils.
- With the clamping nut in the open position install a clean service-able cutting tool into the open clamping bore.
- Be careful to install the shank deep enough to use the entire clamping bore but not to allow the flutes to enter the bore.
- To tighten, rotate clamp nut clockwise until the face of the Clamping Nut is flush with the face of the clamp bore.
- Care should be taken to make sure the cutting tool is properly installed into clamp bore.

Chuck Clamp Diameter	Recommended Installation
1/8"	.70"
3/16"	.78"
1/4"	1.40"
5/16"	1.58"
3/8"	1.58"
1/2"	1.78"

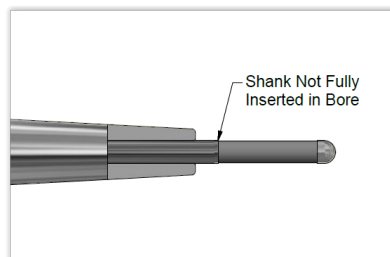

Incorrect: Tool not inserted far enough.

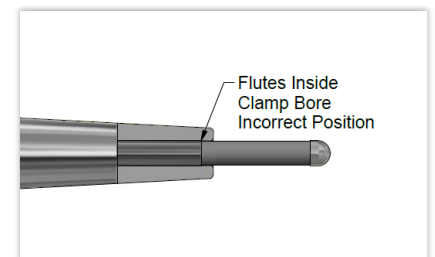

Incorrect: Tool inserted too far.